

Wall corner detail in page 5

Section A - A in page 2  
 Section B - B in page 5  
 Section C - C in page 8  
 Corner detail in page 11

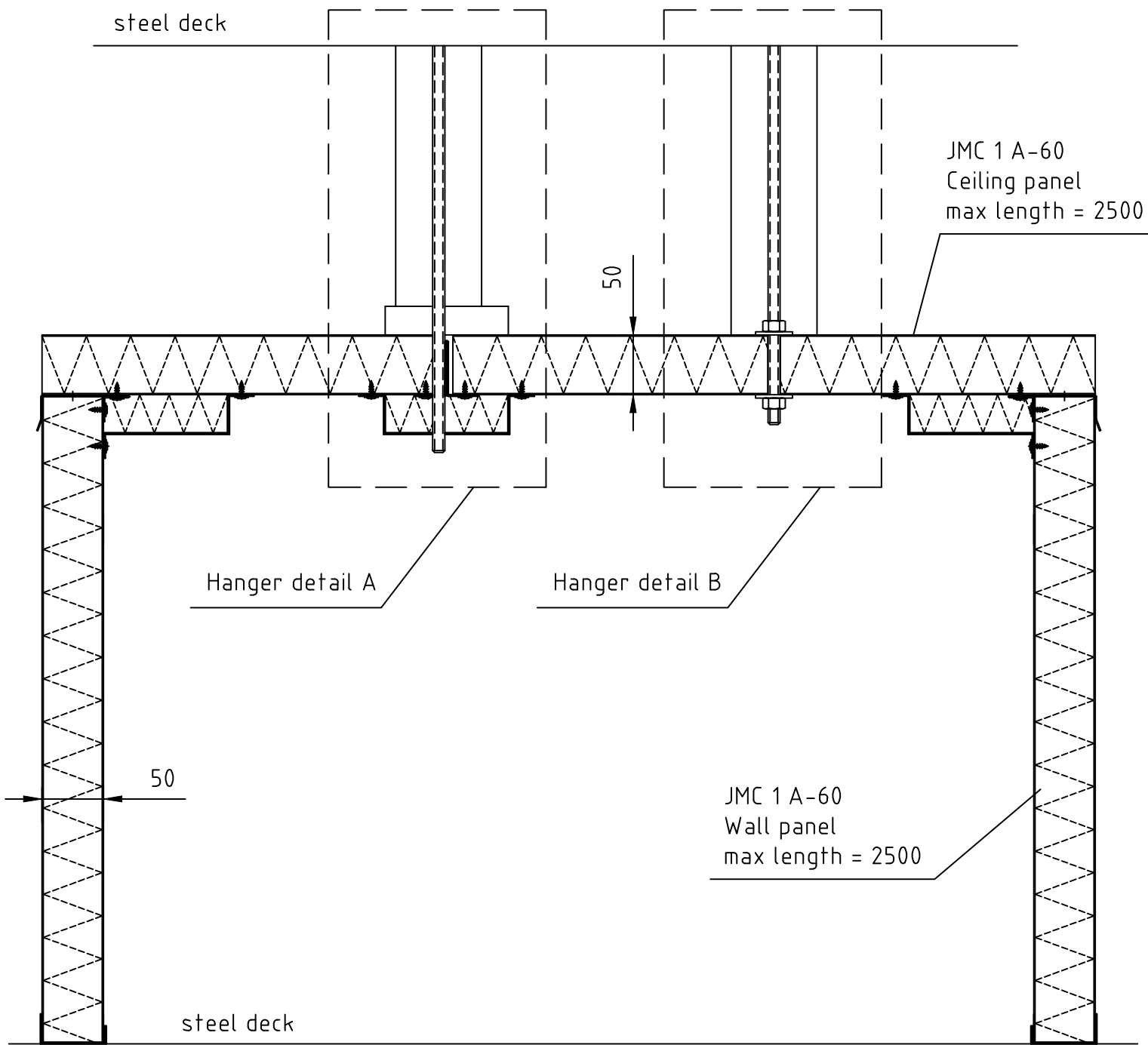

Hanger detail A in page 3

Hanger detail B in page 4

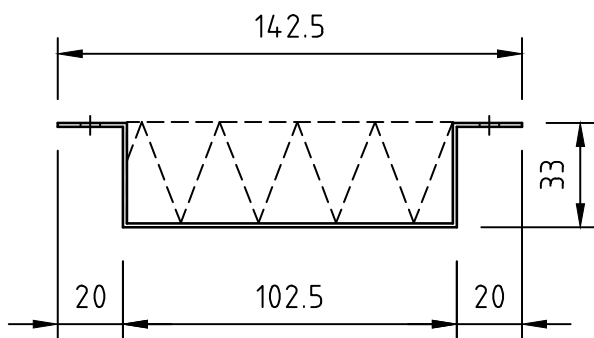
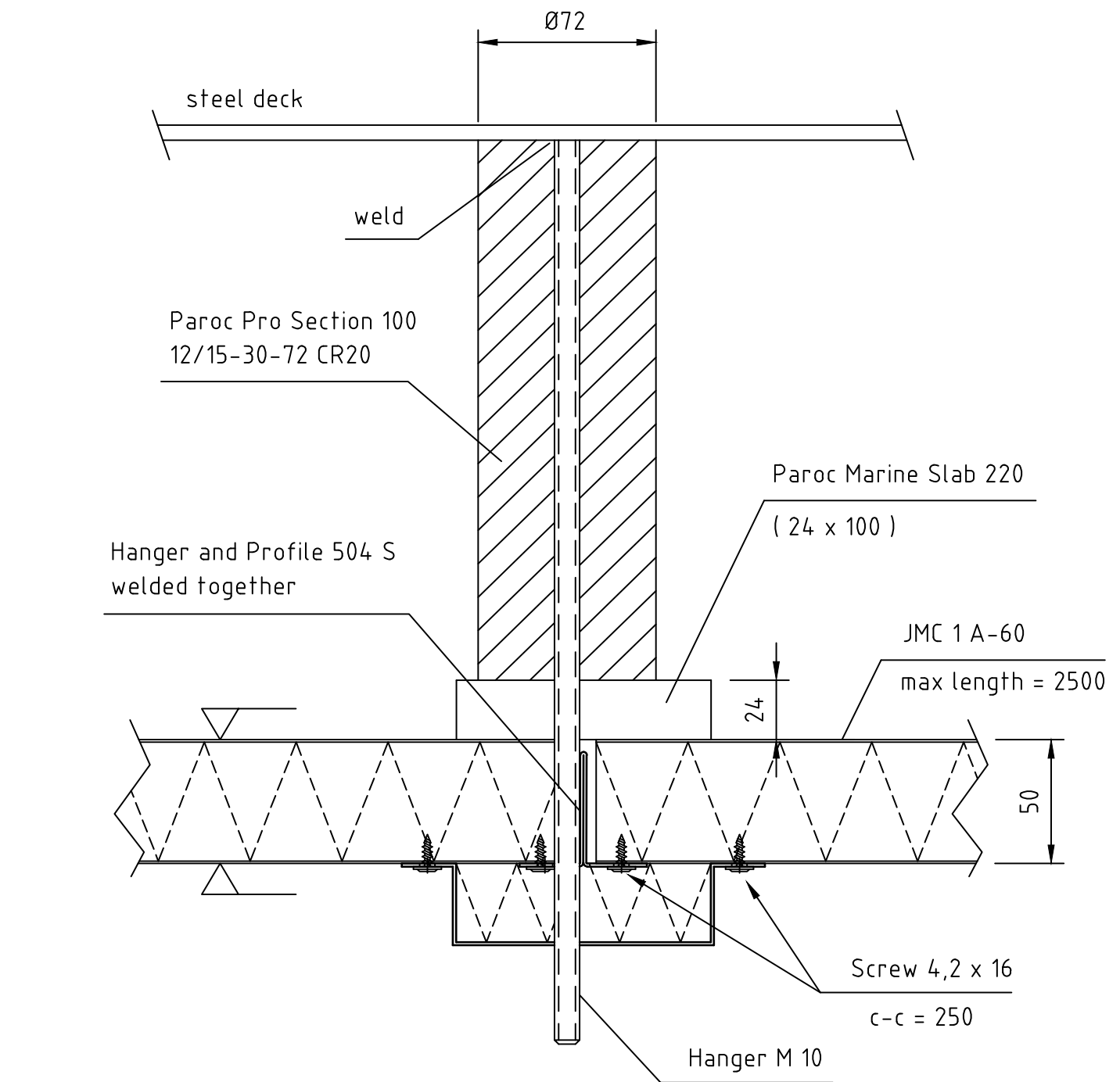

Joint cover profile  
steel 1,25 mm

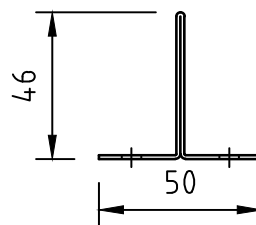

Profile 504 S  
steel 1,25 mm

PVC or painted  
thickness 0,6 mm

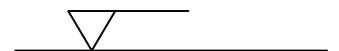

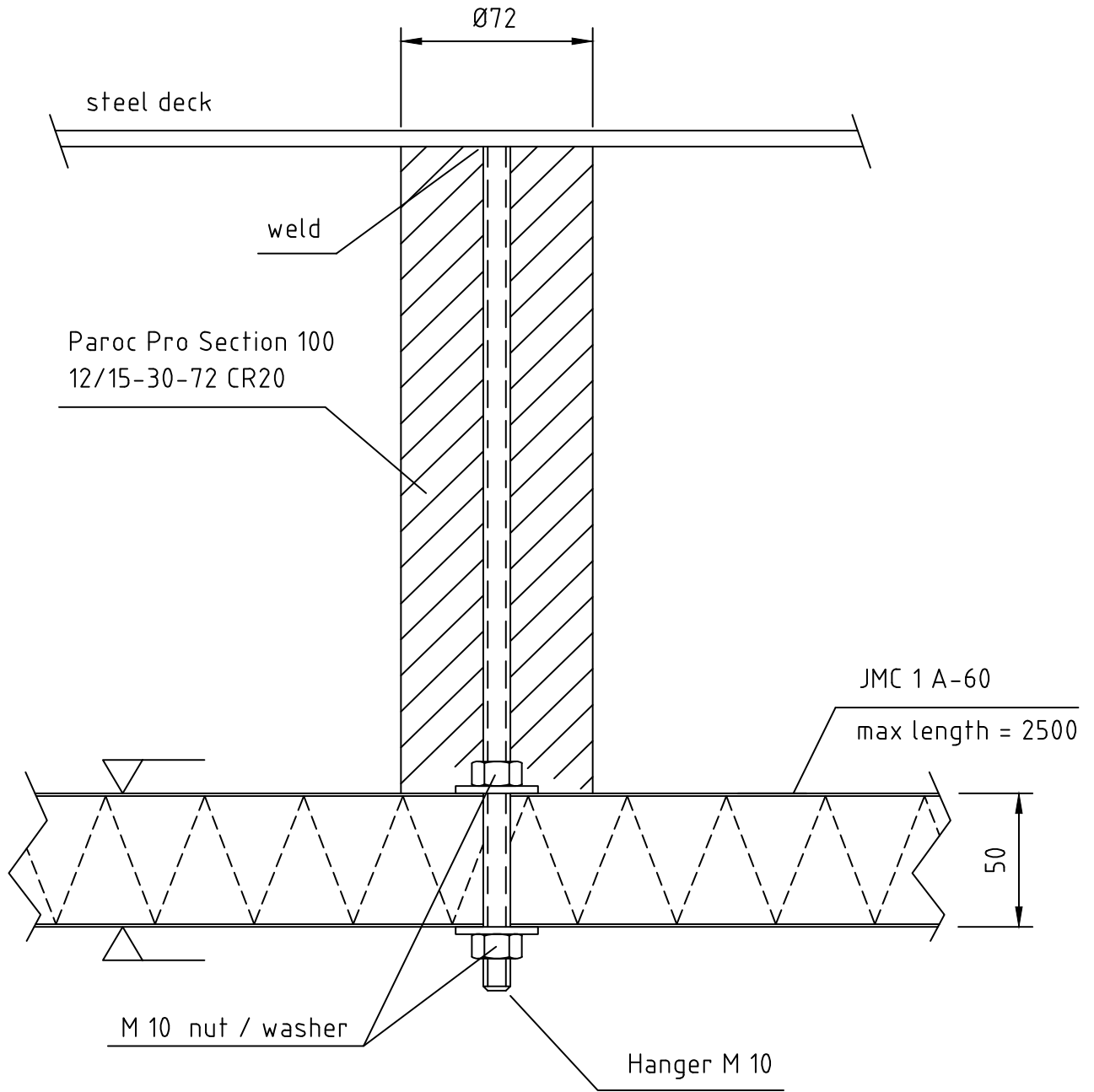

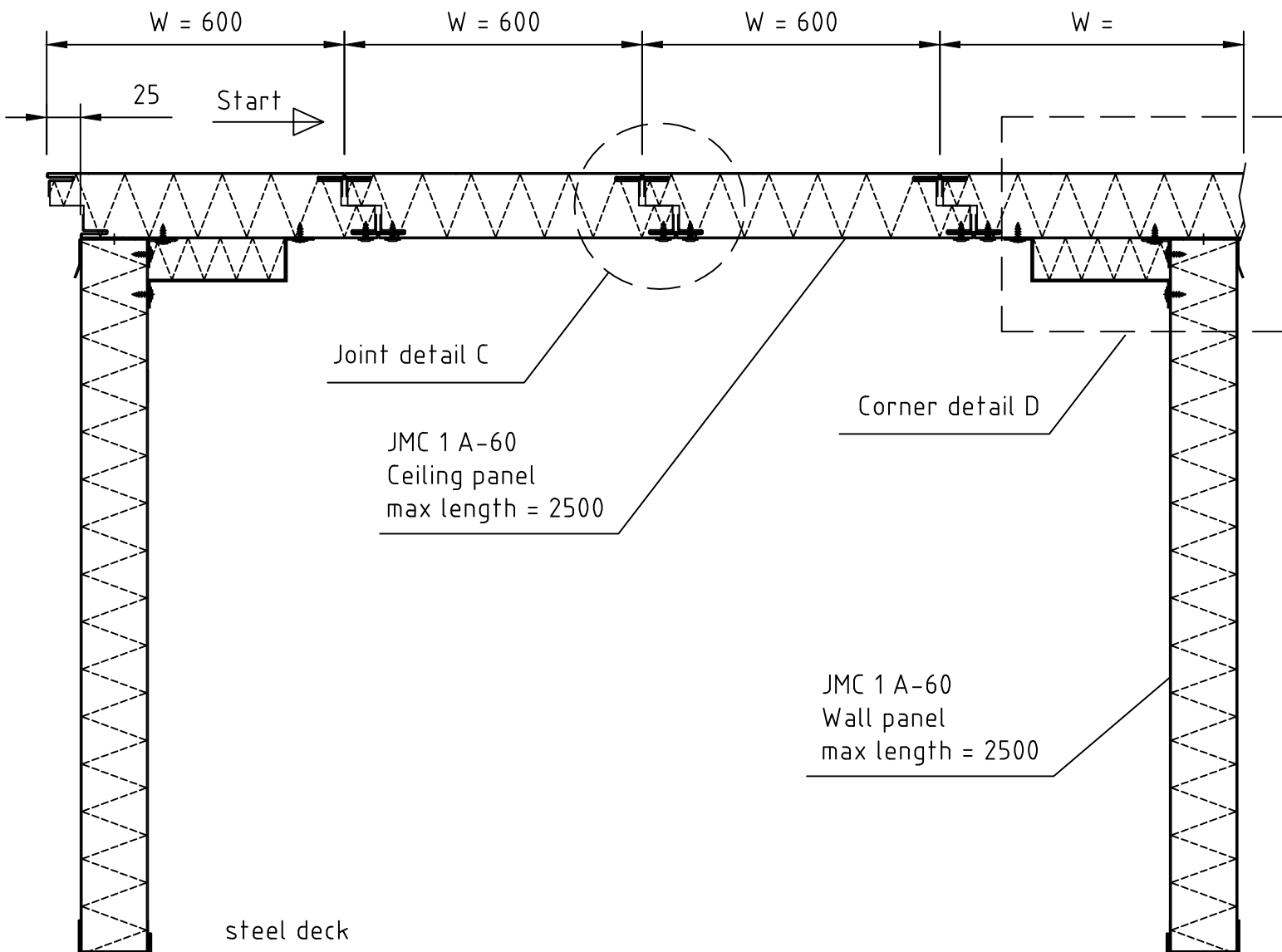

Joint detail C in page 6  
Corner detail D in page 7

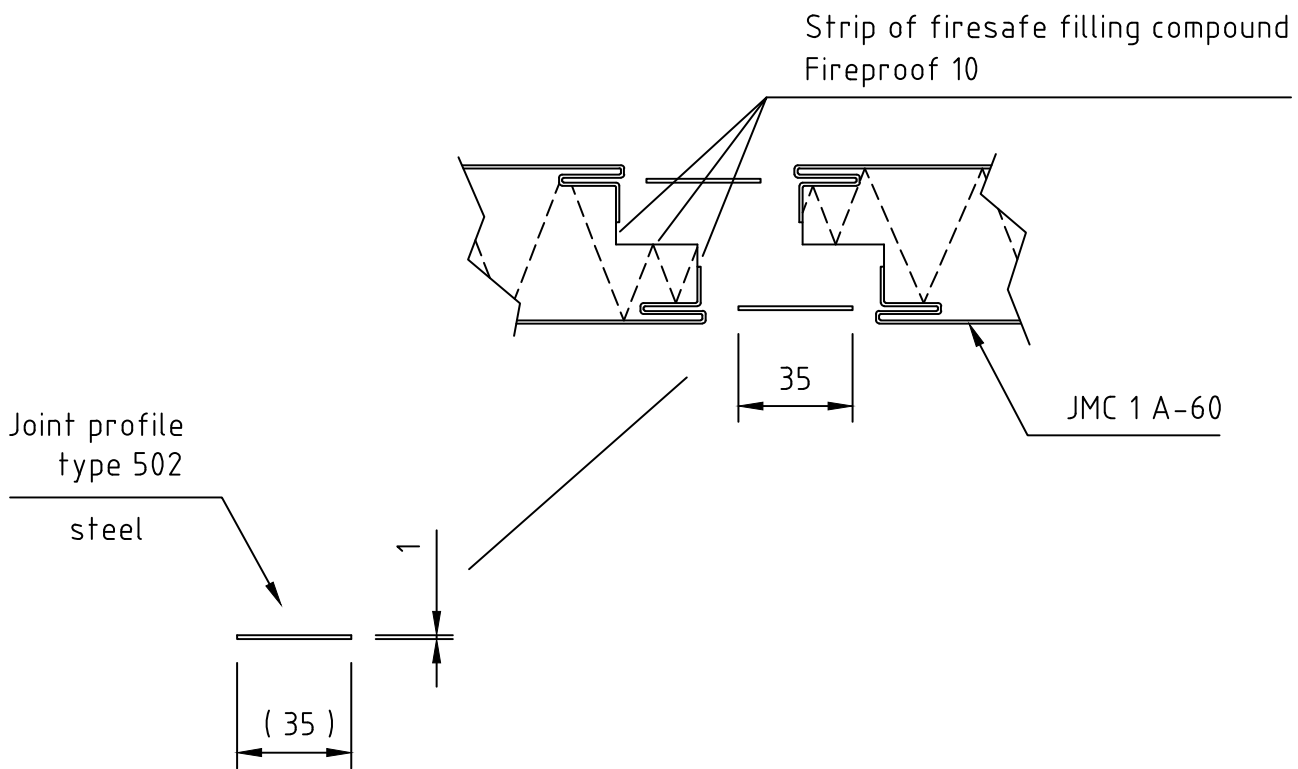
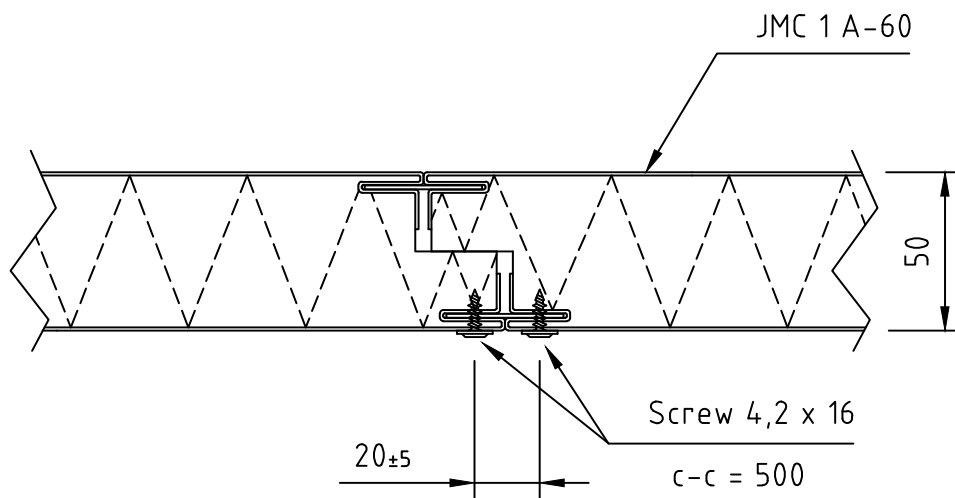

PVC or painted  
thickness 0,6 mm

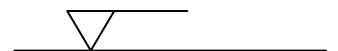

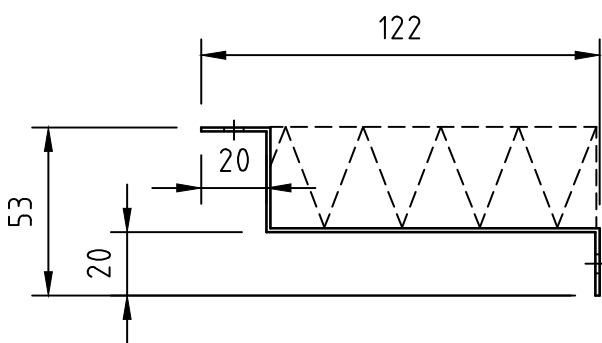
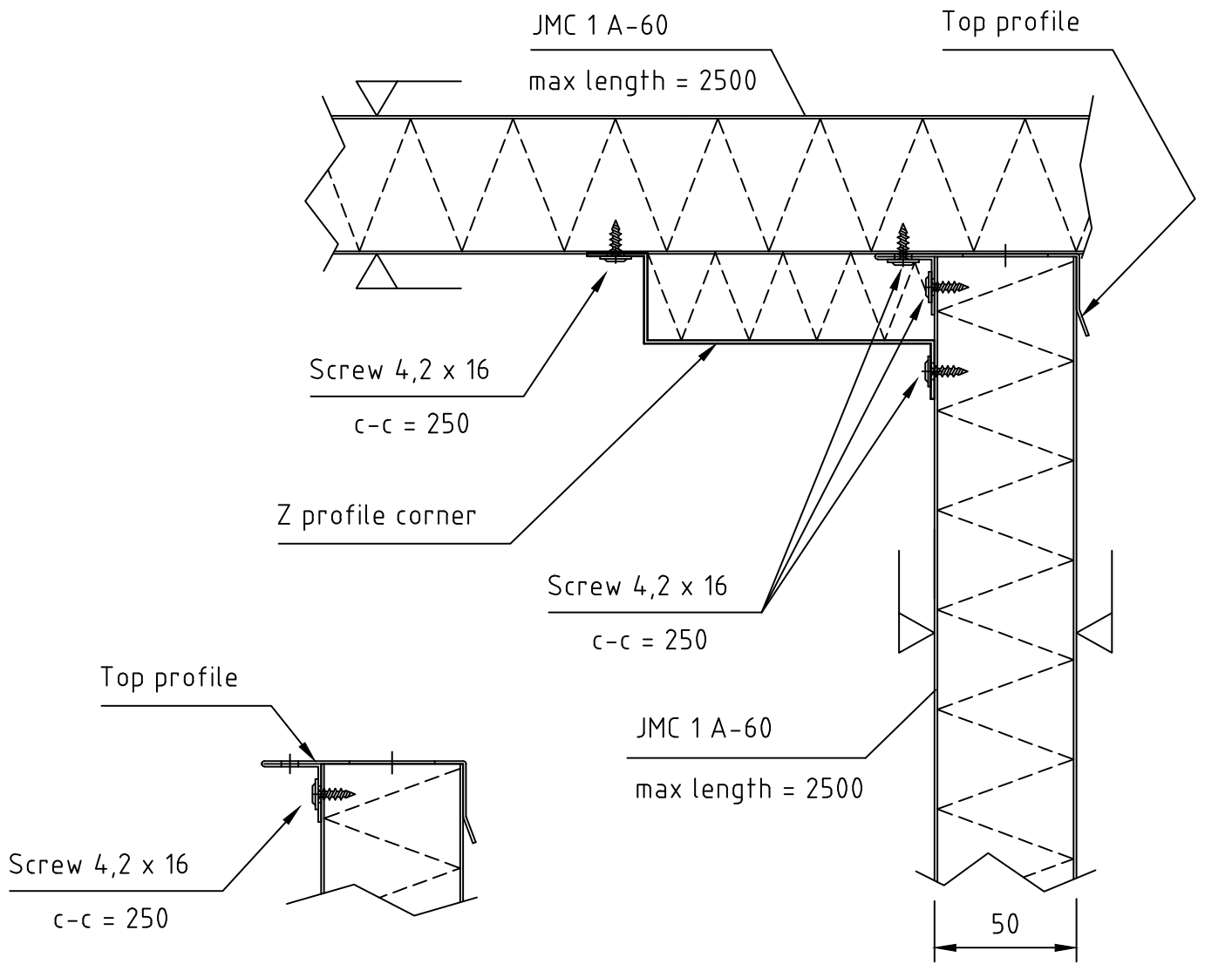

Z profile corner  
steel 1,25 mm

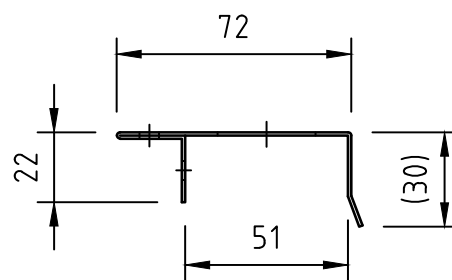

Top profile  
steel 1,25 mm

PVC or painted  
thickness 0,6 mm

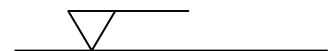

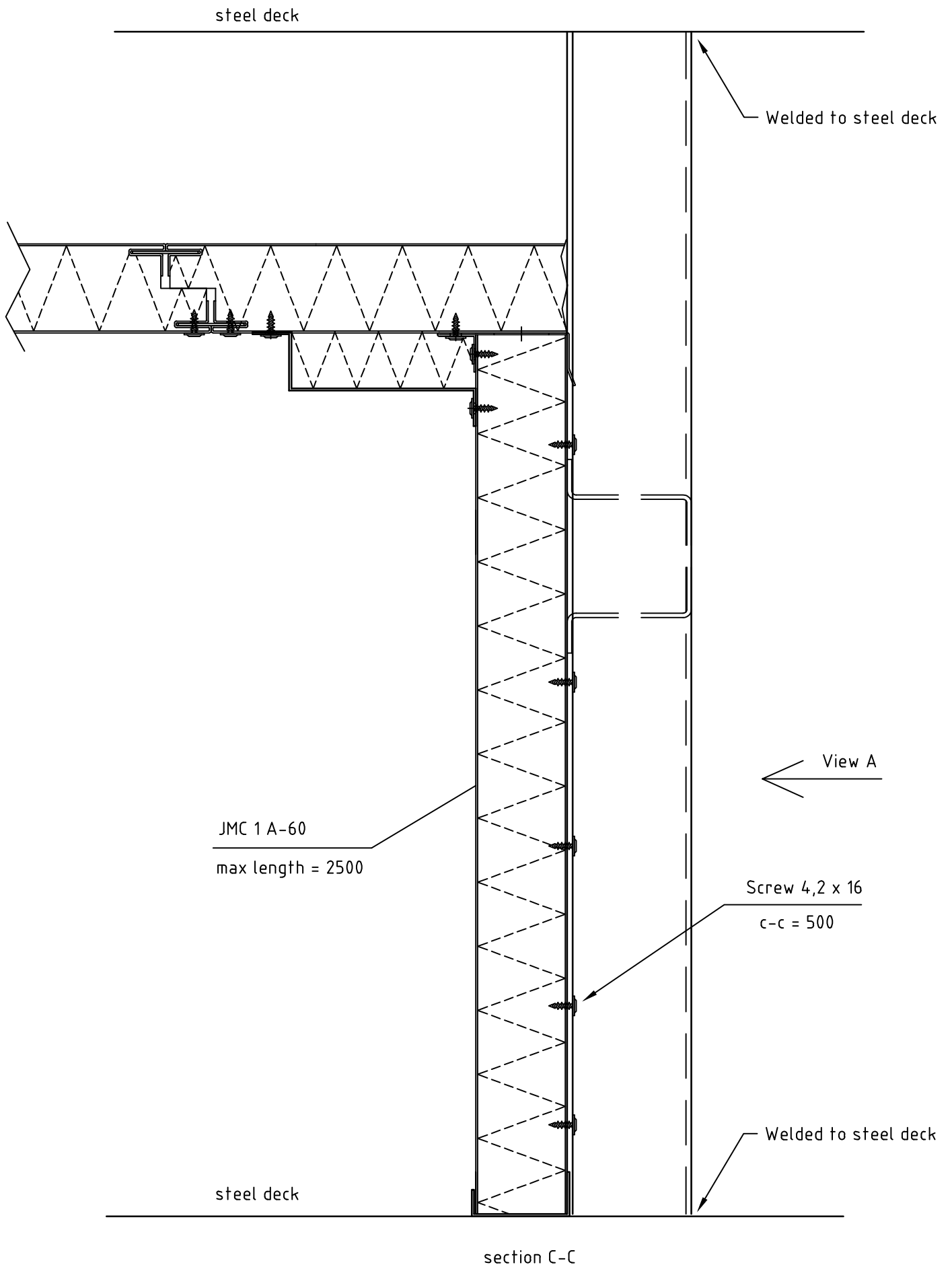

View A in page 9



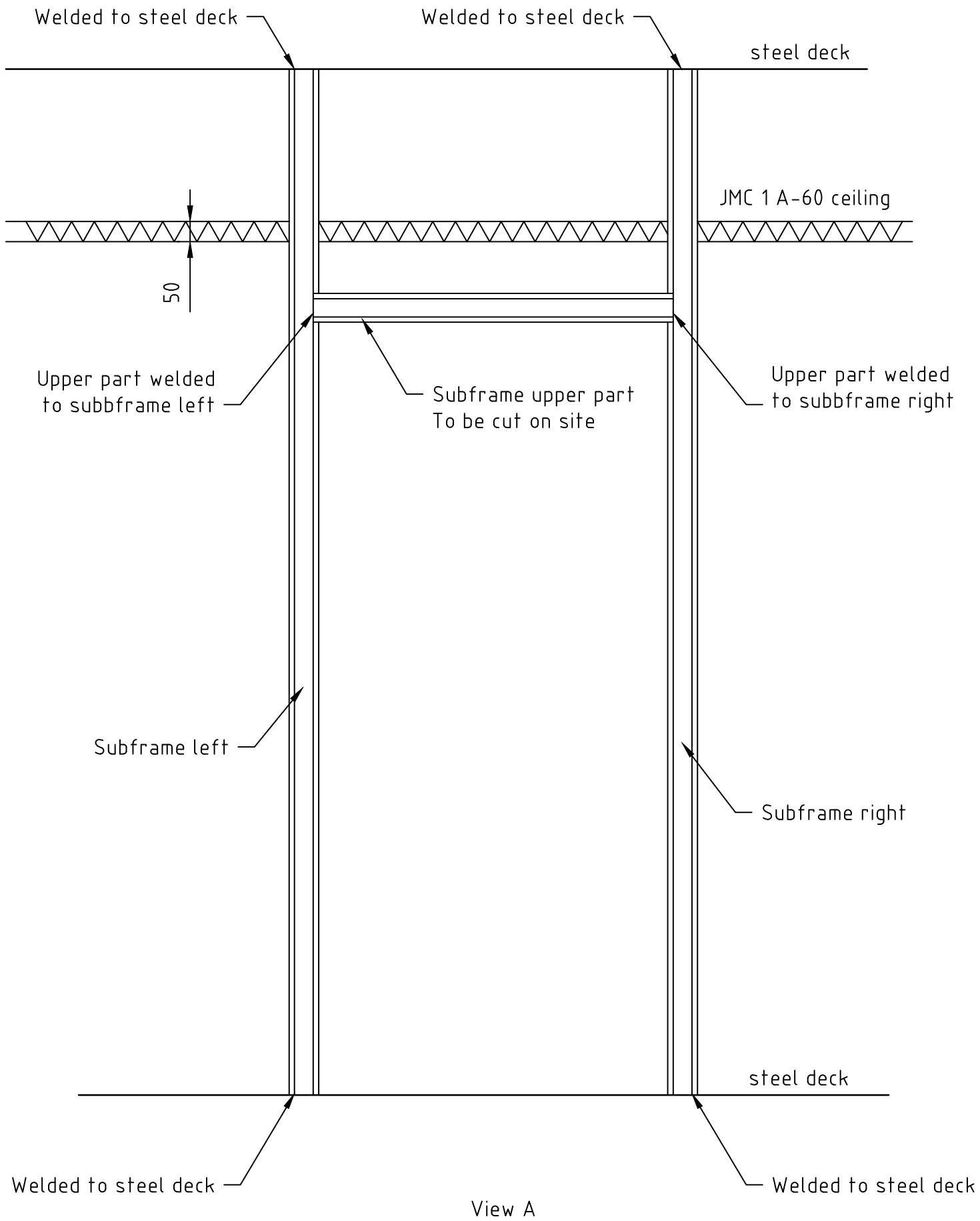

Instructions how to assembly A-60 Fire door in page 10

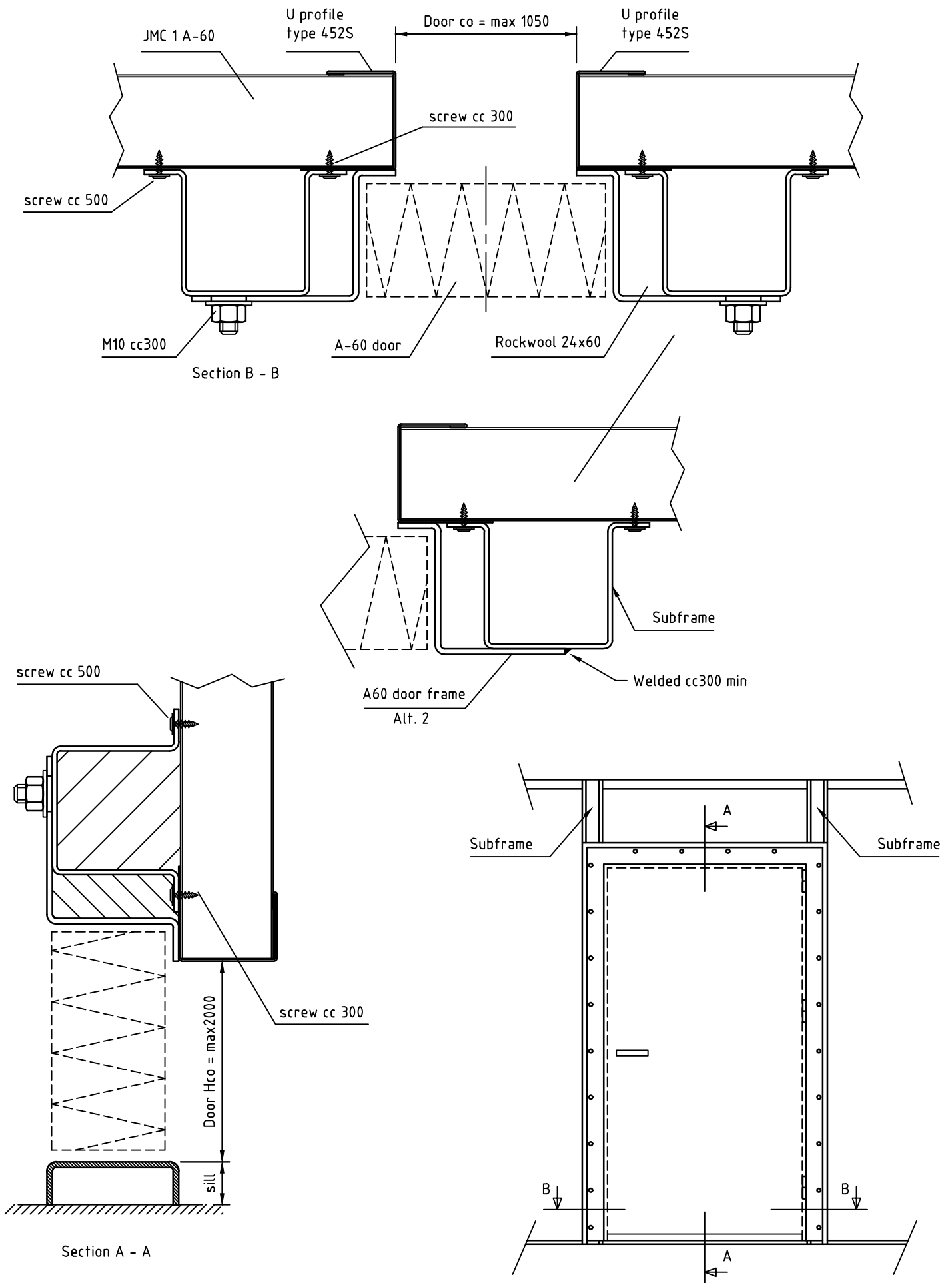

JMC A-60 Box  
 JMC 1 A-60  
 A-60 Door connection

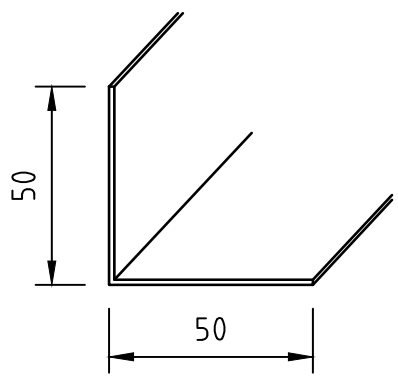
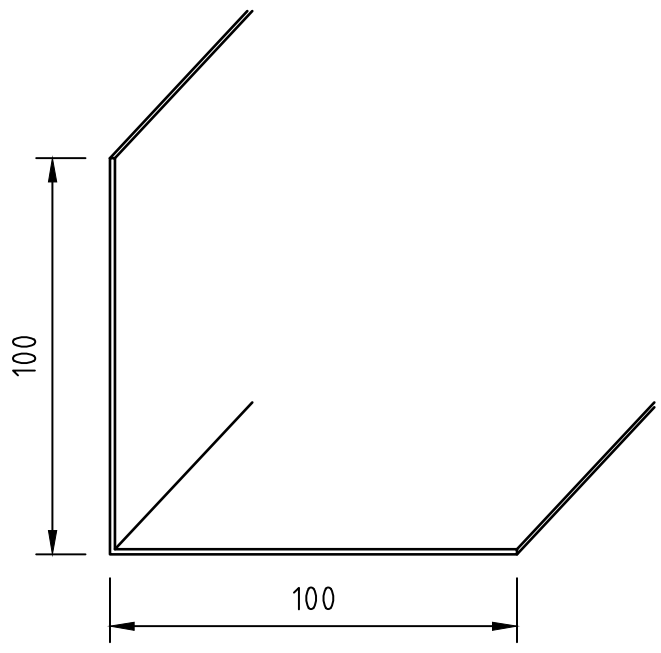
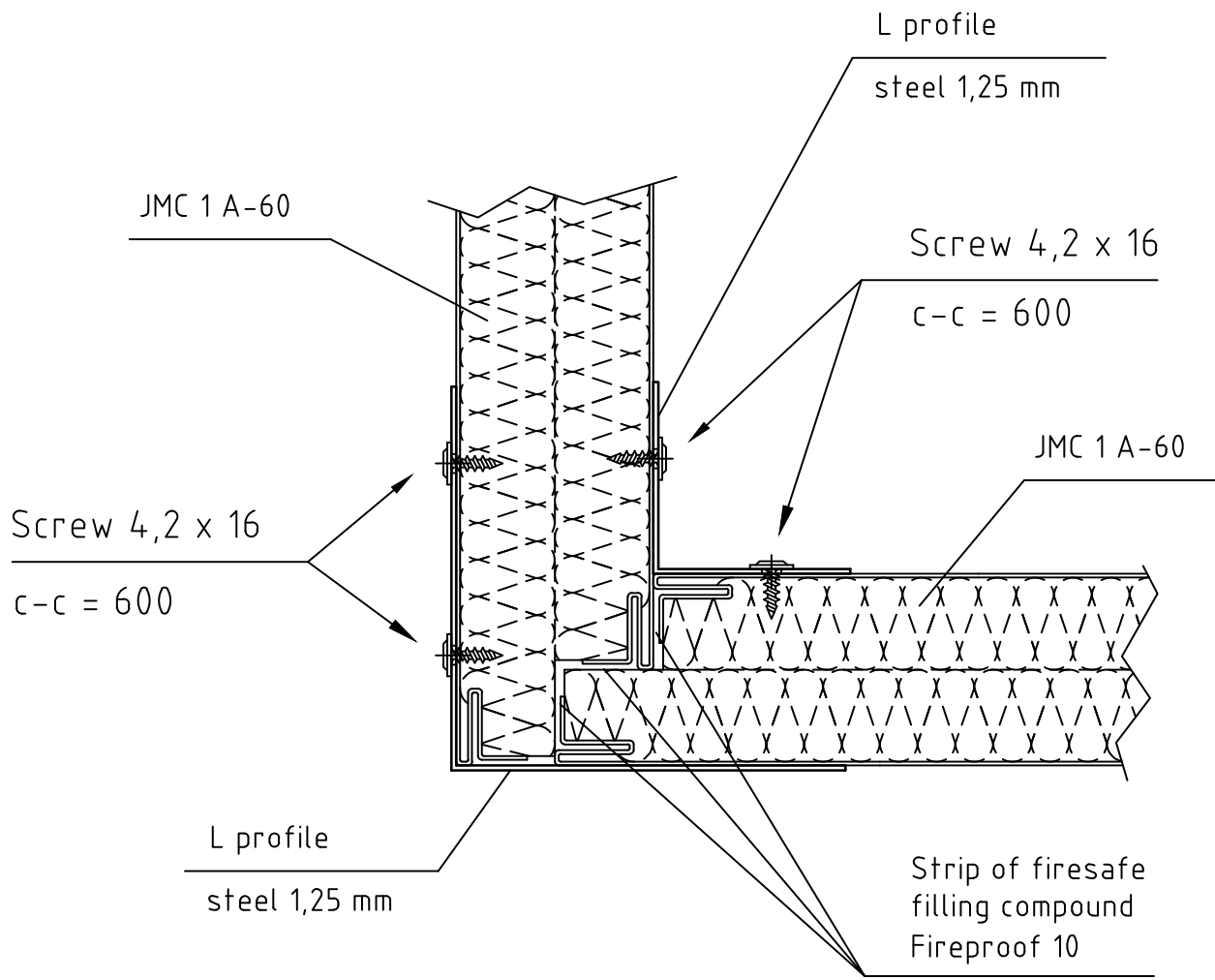

L profile  
Galv 1,25 mm

L profile  
Galv 1,25 mm

PVC or painted  
thickness 0,6 mm